

LED LIGHT PANEL SYSTEM



BY



Light Beam

Industries

KEY FEATURES

CUSTOM SIZES AND SHAPES

EVEN LIGHT DISTRIBUTION

SIZES UP TO 48" X 100"

INNOVATIVE LED TECHNOLOGY

UL CERTIFIED

5000K COLOR TEMP

LOW POWER CONSUMPTION

DIMMABLE

SELF CONTAINED AND SUPER SLIM

50,000 HR LIFE SPAN

STANDARD 2 YEAR WARRANTY

APPLICATIONS

ILLUMINATED DISPLAY

POP DISPLAY

ATM LIGHTING

SALES FLOOR SIGNAGE

GROCERY STORE GRAPHICS

GENERAL ILLUMINATION

MENU BOARD

GRAPHIC ILLUMINATION

AIRPORT ADVERTISING

MOVIE THEATRE GRAPICS

DEPARTMENT STORE GRAPHICS

DESIGN STUDIO LIGHT TABLE

SUPER SLIM DESIGN



Inquiries please contact:

Light Beam Industries

633 Market Street, Suite C Eugene, OR 97402

p: 541.228.3650 f: 541.228.3691

www.lightbeaminc.com

LED LIGHT PANEL SYSTEM



CHANGE YOUR GRAPHICS WITH EASE!

FOR SIGNAGE APPLICATIONS, THE LIGHT BEAM LIGHT PANEL CAN BE SURFACE MOUNTED OR HUNG ON ITS OWN, WITH OR WITHOUT A CONVENIENT SNAP FRAME.

OPTIONS ARE AVAILABLE FOR INDOOR AND OUTDOOR SIGNAGE APPLICATIONS. THE BRIGHT, EVEN ILLUMINATION IS PERFECT FOR ALL TYPES OF SIGNAGE, ELIMINATING HOT SPOTS IN YOUR GRAPHICS AND REDUCING THE DEPTH OF YOUR LIGHT BOX TO 1" OR LESS. MOUNTING THESE LOW PROFILE LIGHT BOXES IS AS EASY AS HANGING A PICTURE FRAME.

SPECIFICATIONS (FOR STANDARD LED PANELS)

SIZE (INCH)	AVERAGE BRIGHTNESS (LX)	POWER CONSUMPTION (W)
4" X 4"	3200	1.5
8.5" X 11"	3500	7.5
18" X 24"	2500	18
22" X 28"	2300	22.5
24" X 36"	2000	29.5
30" X 40"	1800	33
24" X 24"	2500	18
12" X 48"	3500	39
24" X 48"	2500	39
48" X 96"	1800	81

CROSS SECTION OF PANEL IN SNAP FRAME (PANELS COME WITH OR WITHOUT FRAME)

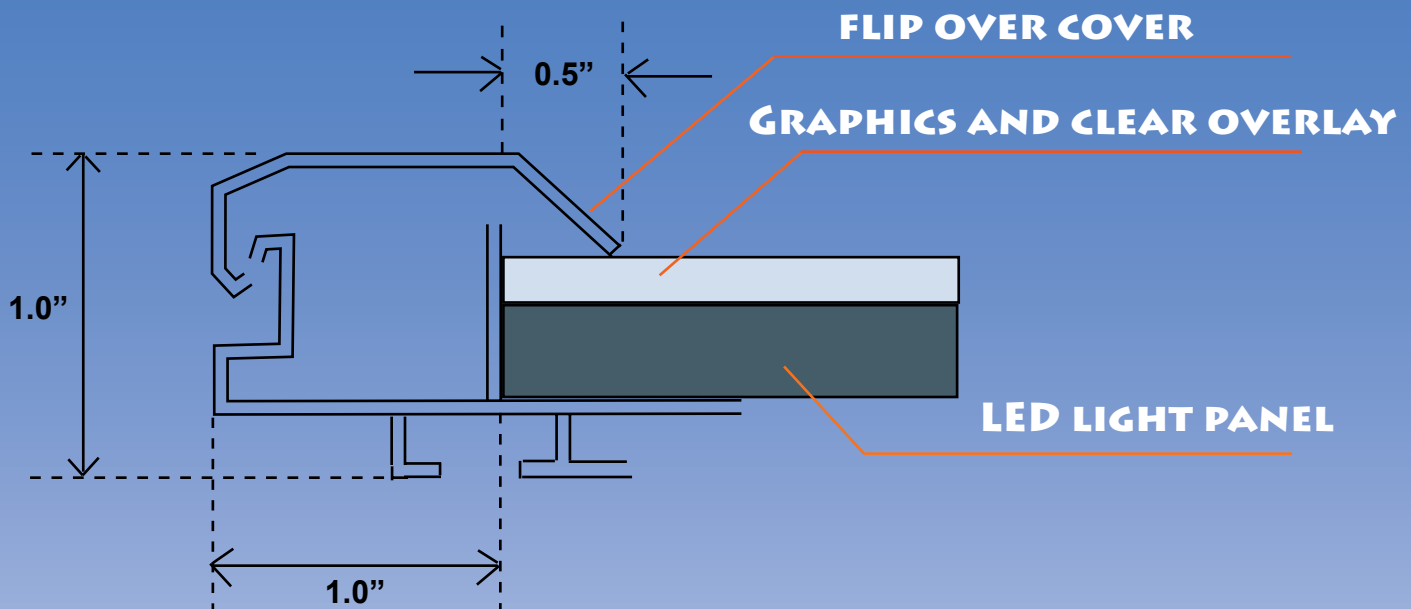

CUSTOM SIZES AND SHAPES AVAILABLE!